

Pluma Número de Cabrestantes	A	B	C	D	E		F		G	
					4x2x2	4x4x4	4x2x2	4x4x4	4x2x2	4x4x4
30.00m 1 Cabrestante	11030mm (36ft 2in)	2385mm (7ft 10in)	3490mm (11ft 5in)	3545mm (11ft 8in)	12000mm (39ft 5in)	8920mm (29ft 3in)	11518mm (37ft 10in)	8555mm (28ft 1in)	9327mm (30ft 7in)	5546mm (18ft 2in)
30.00m 2 Cabrestantes	11200mm (36ft 2in)		3650mm (12ft)	3770mm (12ft 4in)	11450mm (37ft 7in)	8377mm (27ft 6in)	11010mm (36ft 1in)	7375mm (24ft 3in)	9327mm (30ft 7in)	5546mm (18ft 2in)
27.44m 1 Cabrestante	10000mm (32ft 10in)	1692mm (5ft 7in)	3150mm (10ft 4in)	3232mm (10ft 7in)	11450mm (37ft 7in)	8377mm (27ft 6in)	11010mm (36ft 1in)	7375mm (24ft 3in)	9327mm (30ft 7in)	5546mm (18ft 2in)
27.44m 2 Cabrestantes	10500mm (34ft 5in)		3650mm (12ft)	3770mm (12ft 4in)	11450mm (37ft 7in)	8377mm (27ft 6in)	11010mm (36ft 1in)	7375mm (24ft 3in)	9327mm (30ft 7in)	5546mm (18ft 2in)

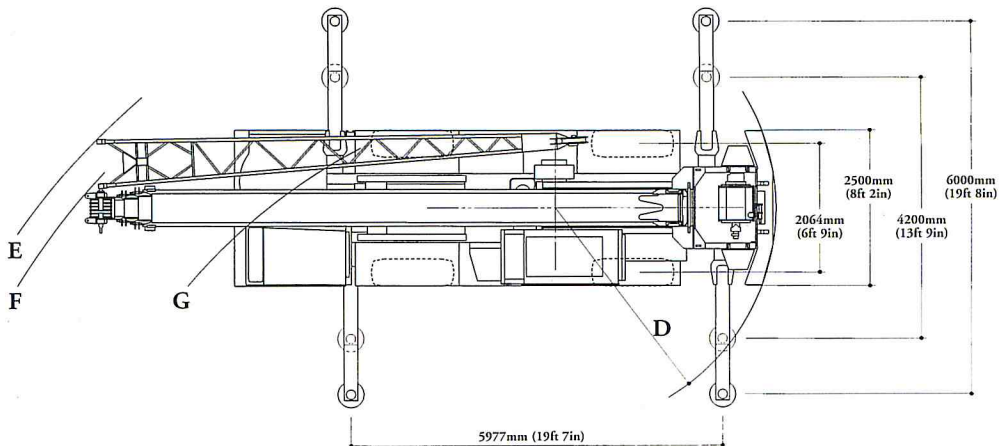

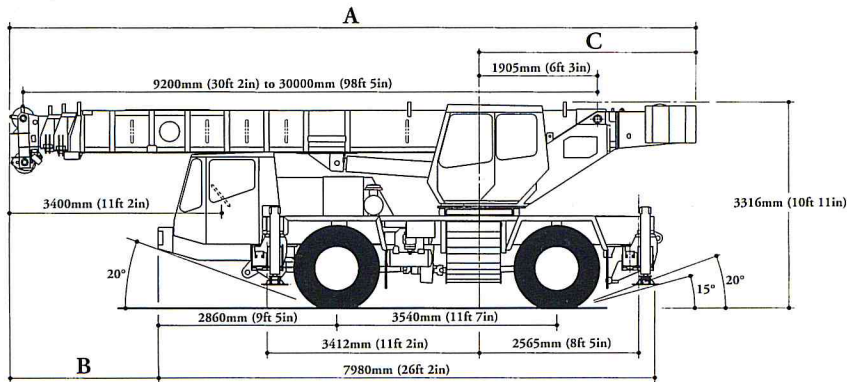

GROVE
CRANE

A GROVE WORLDWIDE COMPANY

AT635/AT635B

ALL-TERRAIN HYDRAULIC CRANE
HYDRAULISCHER GELÄNDEKRAN
GRUE HIDRAULICA TODO TERRENO
85% METRIC

WORKING RANGE DIAGRAM
ARBEITSBEREICHSDIAGRAMM *DIAGRAMA DE ALCANCES*

